

# VISOR® object sensor

In a class of its own.

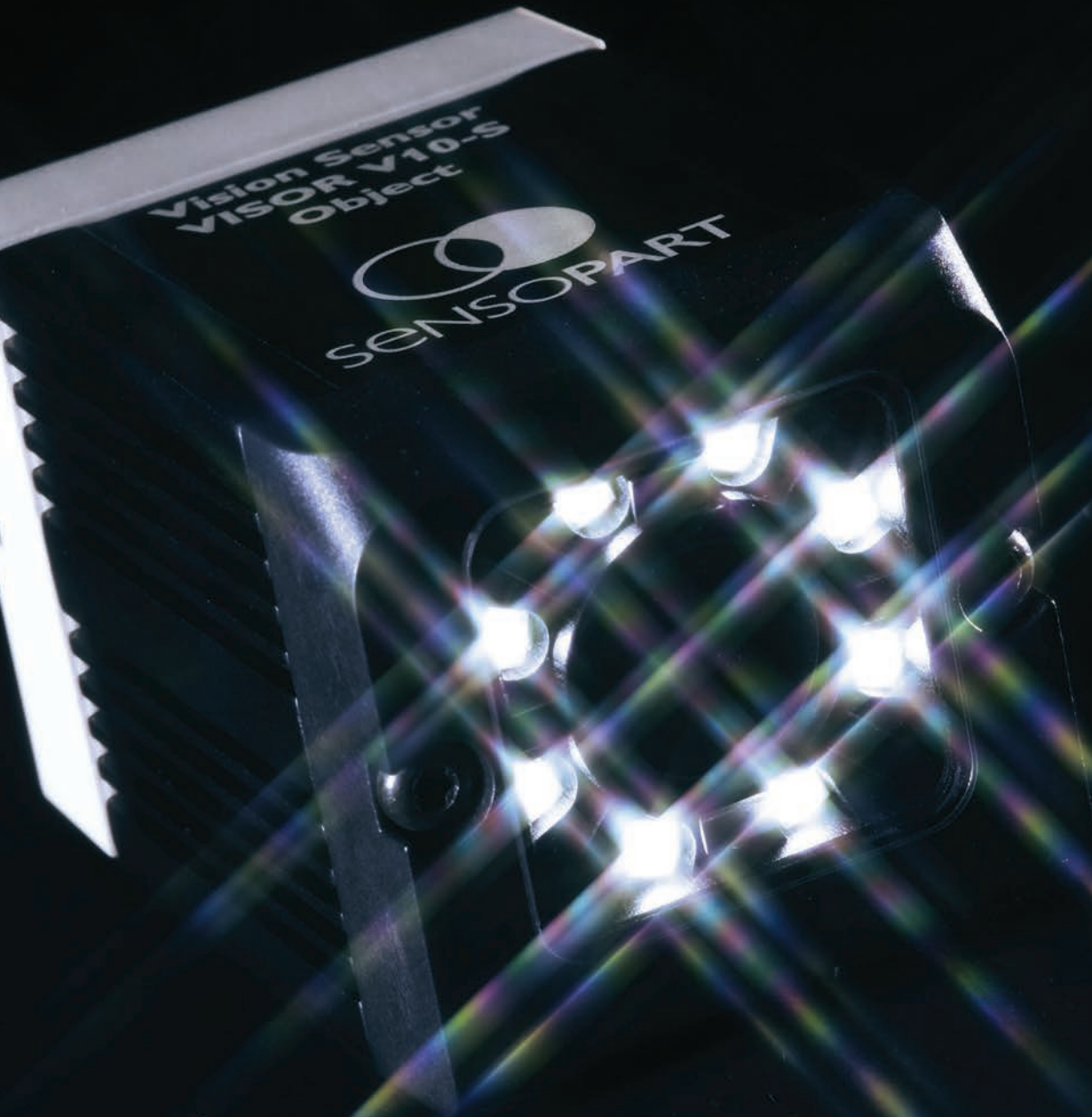

1.3 Mpx

**It's set up!**

VISOR®. The vision sensor with which you can immediately get going.



**Unpack, set up and get going** – never before have vision sensors been so powerful and so easily and intuitively operated. The VISOR® is ready for operation in just ten minutes with a few mouse clicks. With VISOR® technology from SensoPart there is now a simple and effective solution for even the most difficult of automation tasks. Whether objects with a complex shape, data matrix codes, self-lighting display elements or edge defects on solar cells – our application-specific vision sensors reliably detect all relevant object features.



# VISOR® object sensor

## System description

The VISOR® vision sensor from SensoPart not only impresses with its excellent performance data, but also with its sophisticated operating concept: even the definition of complex inspection tasks is achieved rapidly and without complication thanks to its comfortable and easily understood user interface – even without detailed image-processing knowledge. You define and test your inspection tasks (jobs) and desired evaluations (detectors) in a few intuitive setup steps.

The effect of every setting is immediately visible in the image. Comprehensive logic functions allow the direct assignment of more complex inspection results to one of six digital result outputs (or even to 32 switching outputs via the I/O expansion module available as an accessory). Time-based control of signal output is also possible via the integrated encoder function. The integrated image recorder, with which you can carry out fault analyses and simulations, is also very helpful.

**Everything in view with the Viewer:** after completing configuration, the vision sensor works in your production plant autonomously, i.e. without a PC connection. Of course, data can be called up at any time during running operation: our own Viewer software with heriarchical user rights (reliably preventing unintentional changes to the configuration) is available for this. Professional image processing can be so simple and comfortable!

### Step-by-step to your goal

- 1. Job:** select an inspection task or create a new one.
- 2. Position tracking:** define a position detector (optional).
- 3. Detectors:** define the desired evaluations.
- 4. Output:** assign the inspection results to the switching outputs.
- 5. Results:** test your configuration.
- 6. Start the sensor:** run your job on the sensor.

### Product variants: the VISOR® object sensor

Features/sensors	Standard	Advanced
<b>Functions</b>		
Resolution V10 in pixels	736 x 480	736 x 480
Resolution V20 in pixels	–	1280 x 1024
Image rate per second	25	50
Number of jobs   detectors	2   32	n   n
Position tracking	–	✓
Pattern comparison (X-,Y-translation)	✓	✓
Contour matching (X-,Y-translation, orientation)	✓	✓
Grey threshold	✓	✓
Contrast	✓	✓
Brightness	✓	✓
Freeform Tool	Contour only	✓
<b>Interfaces</b>		
Inputs   outputs	2   4	2   4
Freely definable switching outputs/ inputs, PNP or NPN	2	4
Encoder input	–	✓
I/O expansion	–	✓
RS422	–	✓
Ethernet/data transmission	✓	✓
EtherNet/IP	✓	✓
PROFIBUS/interface connection	–	✓
<b>Lens</b>		
Integrated 6 mm   12 mm   25 mm	✓   ✓   –	✓   ✓   ✓
C-mount	–	✓
<b>Operation/visualisation</b>		
Viewer software with user guidance	✓	✓
Hierarchical user rights	✓	✓

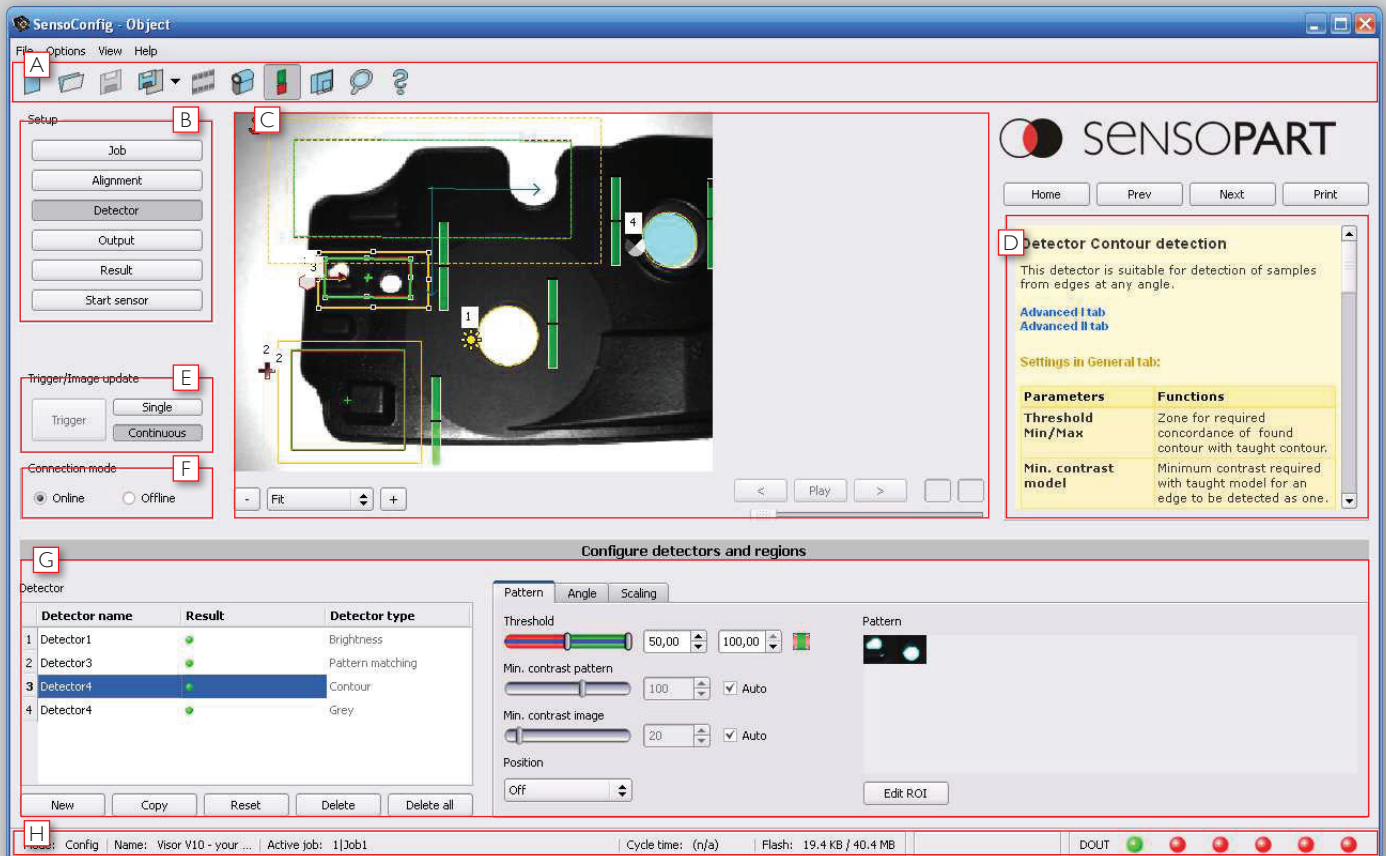



## Overview of the user interface

- A** **Menu bar:** rapid access to the most important functions
- B** **Setup navigation:** dependable user guidance through the configuration process
- C** **Image window:** live picture of the object with graphic display of inspection area and results
- D** **Context help:** precise information on every work step
- E** **Trigger function:** triggered operation or free-running, single picture or serial switching
- F** **Online/offline operation:** operating with sensor connected or simulation with stored pictures
- G** **Configuration window:** input of parameters for every navigation step
- H** **Status line:** current information on active job and on state of outputs

# VISOR® object sensor for part detection

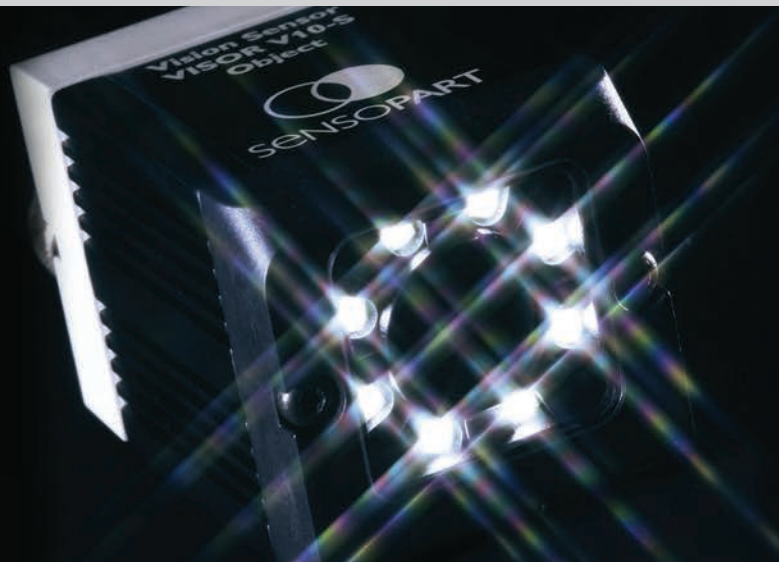
Detects the right part in the wrong place and vice versa



 made in Germany



## **Glue dot present?**

Early detection by monitoring presence – in this case caps for the beverages packaging industry – long before quality assurance. Preventing expensive rejections.



## **Position and position tolerance measurement:**

The sensor “learns” the contours and their direction from a picture, and reacts reliably to deviations. The sensor responds correctly even if a nut is the wrong way round.



## **Spout present or not?**

Too much shrinking – or too little? The Vision object sensor's contour detector keeps an eye on all the relevant details during the production of blood bags.

## HIGHLIGHTS OF VISOR® OBJECT SENSOR

- User-friendly configuration and viewer software with hierarchical user rights and online Help
- Powerful part-finding and tracking
- Precise position determination: x/y-position and orientation
- Comprehensive logic functions for the digital switching outputs
- Flexible definition of output data (header, trailer, net data)
- Support of EtherNet/IP and DHCP
- Comprehensive possibilities for archiving pictures and data

Objects that sometimes appear in unexpected positions and have complex shapes and details – classic switching sensors would be completely overwhelmed by such detection tasks. Not the VISOR® object sensor from SensoPart: it always maintains its overview, detecting defective parts, parts in the wrong position, wrong orientation, wrong sequence or a combination of them all – in an instant. With its highly precise position and orientation detection, our VISOR® object sensor is one of the best in its class.

### Five detectors plus position detection

A total of five detectors are available for inspection tasks and evaluations: pattern comparison, contour detection, brightness, grey threshold and contrast detection. The Advanced version of the VISOR® object sensor also offers position tracking, among other things: this permits reliable detection of those features that are not always present in precisely the taught-in position. All evaluations take place relative to the current part position and orientation, without them having to be defined for every possible position of an individual feature. This powerful tool allows you to solve even demanding applications confidently!

VISOR® Object Sensors – Product Overview				
	Firmware Option	Focal Length	Integrated illumination	Page
<b>VISOR® Object Sensors</b>				
V20-OB-A2-xxx	Advanced	12 mm	White, red or infrared LEDs	8
V20-OB-A2-xxx	Advanced	C-mount	None	10
V10-OB-S1-xxx	Standard	6 mm	White, red or infrared LEDs	12
V10-OB-S1-xxx	Standard	12 mm	White, red or infrared LEDs	14
V10-OB-A1-xxx	Advanced	6 mm	White, red or infrared LEDs	16
V10-OB-A1-xxx	Advanced	12 mm	White, red or infrared LEDs	18
V10-OB-A1-xxx	Advanced	25 mm	White, red or infrared LEDs	20
V10-OB-A1-xxx	Advanced	C-mount	None	22

# VISOR® V20 object sensor

Advanced vision sensor for object detection, 12 mm



## PRODUCT HIGHLIGHTS

- User-friendly configuration and viewer software with hierarchical user rights
- Detectors for object detection
- Powerful part-finding and tracking
- Precise position determination: X/Y-position and orientation
- Comprehensive logic functions for digital switching outputs
- Encoder input

Optical data		Functions	
Resolution	1280 x 1024 pixels	Number of jobs / detectors	n / n
CMOS	2/3", monochrome	Detectors	Contour; pattern comparison, contrast, brightness, grey level
Integrated lens, focal length	12 mm, adjustable focal position	Properties	Position tracking: X/Y and orientation; pattern comparison / contour: teach-in and detection of patterns and contours; grey threshold, brightness: evaluation of brightness; contrast: evaluation of contrast
Adjustment range	30 mm to infinity	Typical cycle times	Typ. 20 ms pattern comparison Typ. 30 ms contour Typ. 2 ms brightness Typ. 2 ms contrast Typ. 2 ms grey threshold
Integrated illumination	White, red, infrared LEDs		
Minimum field of view, X x Y	16 x 13 mm <sup>2</sup>		
Electrical data		Mechanical data	
Operating voltage, +U <sub>B</sub>	18 ... 26.4V DC <sup>1</sup>	Dimensions	65 x 45 x 45 mm <sup>3</sup> (without plug)
Current consumption (without illumination and I/O)	≤ 120 mA	Enclosure rating	IP 67
Current consumption (without I/O)	≤ 200 mA	Material, housing	Aluminium, plastic
Protective circuits	Reverse-polarity protection, U <sub>B</sub> / short-circuit protection of all outputs	Material, front screen	Plastic
Readiness delay	Ca. 13 s after Power on	Ambient temperature: operation	0 ... +50° C <sup>2</sup>
Outputs	PNP / NPN (switchable)	Ambient temperature: storage	-20 ... +60° C <sup>2</sup>
Max. output current (per output)	50 mA, 100 mA (pin 12)	Weight	Ca. 160 g
Inputs	PNP/NPN High > U <sub>B</sub> -1V, Low < 3V	Plug connections	Supply and I/O M12, 12-pin Ethernet M12, 4-pin Data M12, 5-pin
Input resistance	> 20 kOhm	Vibration and impact resistance	EN 60947-5-2
Encoder input	High > 4V		
Interfaces: VISOR® V20-OB-Advanced	Ethernet (LAN), RS422, RS232, EtherNet/IP		
Inputs/outputs	2 inputs, 4 outputs, 4 selectable inputs/outputs		

<sup>1</sup> Max. ripple < 5V<sub>SS</sub>    <sup>2</sup> 80 % air humidity, non-condensing

Illumination	Part number	Article number
White	V20-OB-A2-W12	536-91011
Red	V20-OB-A2-R12	536-91012
Infrared	V20-OB-A2-I12	536-91013

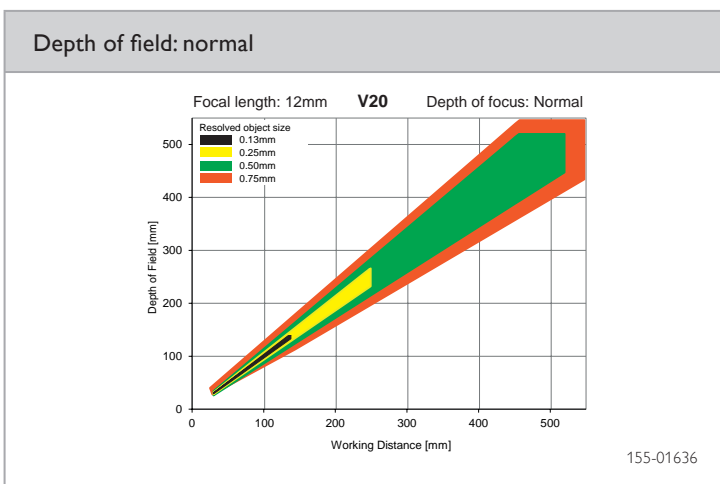
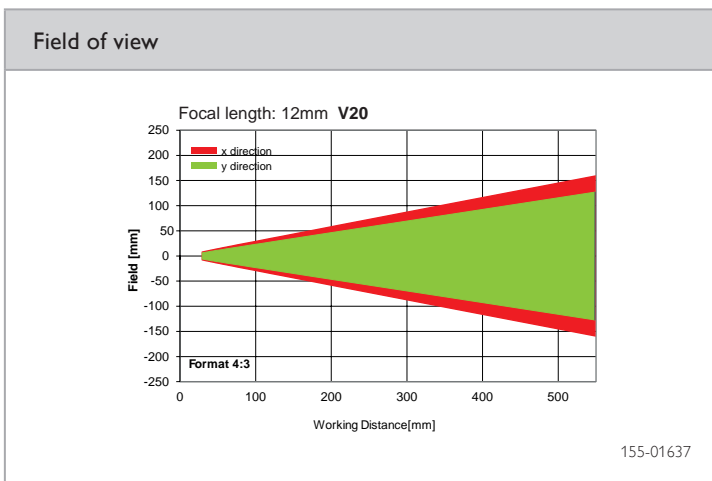
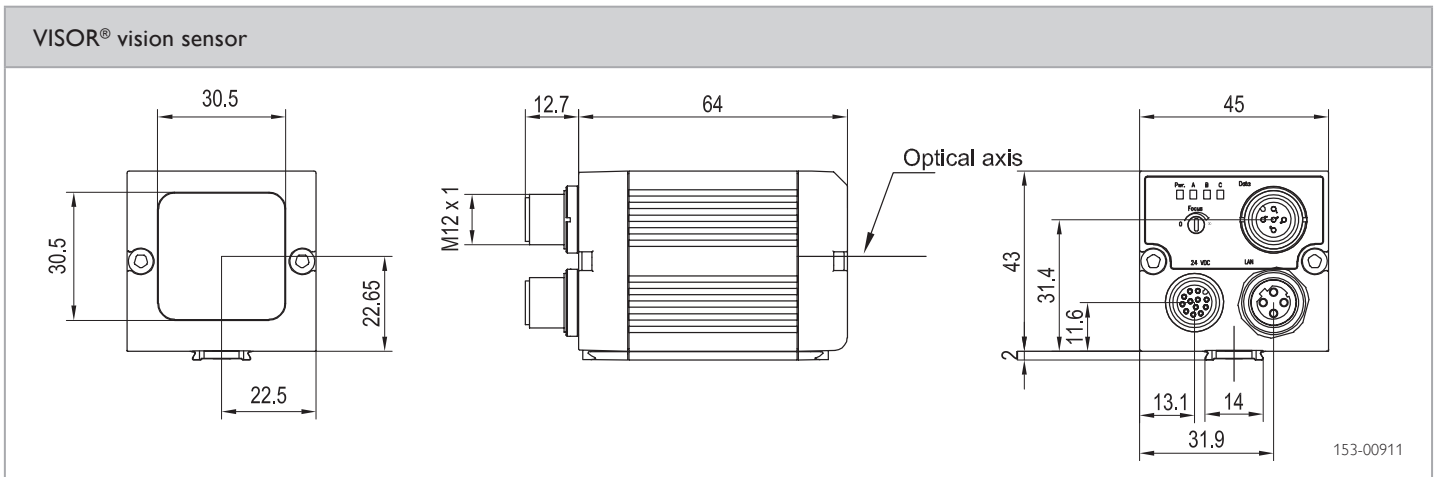

**Accessories**

Connection cables	See product catalog/ accessories
Illumination	
Brackets	
Interface accessories	

# VISOR® V20 object sensor

Advanced vision sensor for object detection, C-mount



## PRODUCT HIGHLIGHTS

- User-friendly configuration and viewer software with hierarchical user rights
- Detectors for object detection
- Powerful part-finding and tracking
- Precise position determination: X/Y-position and orientation
- Comprehensive logic functions for digital switching outputs
- Encoder input

Optical data		Functions	
Resolution	1280 x 1024 pixels	Number of jobs / detectors	n / n
CMOS	2/3", monochrome	Detectors	Contour; pattern comparison, contrast, brightness, grey level
Integrated lens, focal length	C-Mount	Properties	Position tracking: X/Y and orientation; pattern comparison / contour: teach-in and detection of patterns and contours; grey threshold, brightness: evaluation of brightness; contrast: evaluation of contrast
Adjustment range	Dependent on lens	Typical cycle times	Typ. 20 ms pattern comparison Typ. 30 ms contour Typ. 2 ms brightness Typ. 2 ms contrast Typ. 2 ms grey threshold
Integrated illumination	None		
Minimum field of view, X x Y	Dependent on lens		
Electrical data		Mechanical data	
Operating voltage, +U <sub>B</sub>	18 ... 26.4 V DC <sup>1</sup>	Dimensions	65 x 45 x 45 mm <sup>3</sup> (without plug)
Current consumption (without illumination and I/O)	≤ 120 mA	Enclosure rating	IP 65 <sup>2</sup>
Current consumption (without I/O)	≤ 200 mA	Material, housing	Aluminium, plastic
Protective circuits	Reverse-polarity protection, U <sub>B</sub> / short-circuit protection of all outputs	Material, front screen	Plastic
Readiness delay	Ca. 13 s after Power on	Ambient temperature: operation	0 ... +50 °C <sup>3</sup>
Outputs	PNP / NPN (switchable)	Ambient temperature: storage	-20 ... +60 °C <sup>3</sup>
Max. output current (per output)	50 mA, 100 mA (pin 12)	Weight	Ca. 160 g
Inputs	PNP/NPN High > U <sub>B</sub> -1 V, Low < 3 V	Plug connections	Supply and I/O M12, 12-pin Ethernet M12, 4-pin Data M12, 5-pin
Input resistance	> 20 kOhm	Vibration and impact resistance	EN 60947-5-2
Encoder input	High > 4V		
Interfaces: VISOR® V20-OB-Advanced	Ethernet (LAN), RS422, RS232, EtherNet/IP		
Inputs/outputs	2 inputs, 4 outputs, 4 selectable inputs/outputs		

<sup>1</sup> Max. ripple < 5 V<sub>SS</sub>    <sup>2</sup> With LPT45 C-mount protective casing    <sup>3</sup> 80 % air humidity, non-condensing

Part number	Article number
V20-OB-A2-C	536-91010

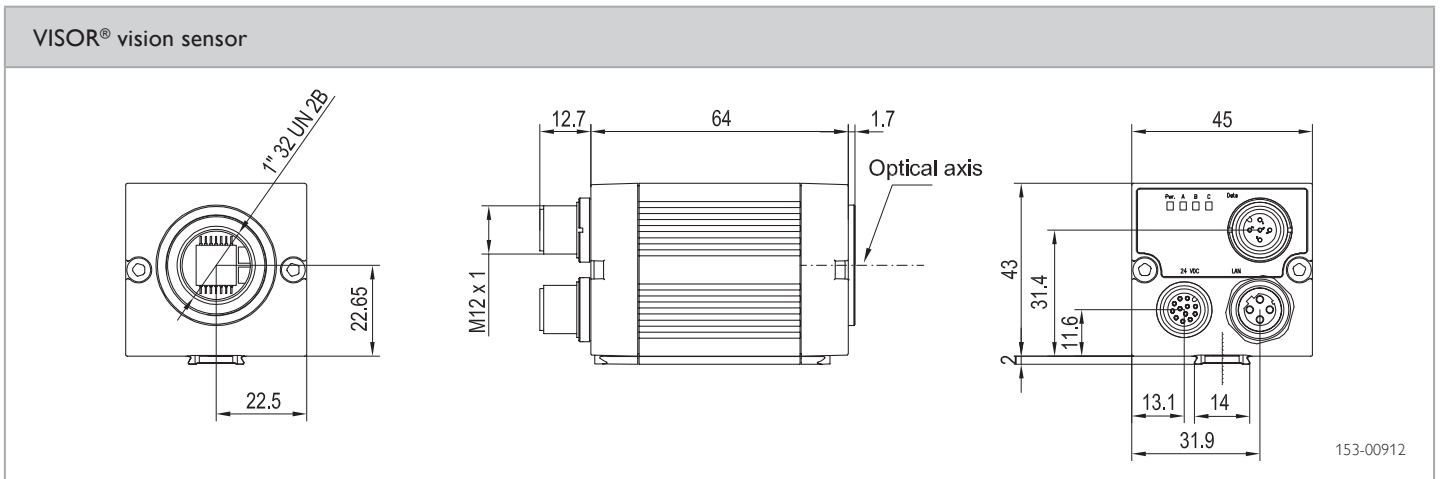

	LO C 8	LO C 12	LO C 16	LO C 25	LO C 50
Focal length	8 mm	12 mm	16 mm	25 mm	50 mm
Article number	526-51513	526-51514	526-51515	526-51516	526-51113

Accessories

Connection cables	See product catalog/ accessories
Illumination	
Lenses	
Brackets	
Interface accessories	

# VISOR® V10 object sensor

Standard vision sensor for object detection, 6 mm



## PRODUCT HIGHLIGHTS

- User-friendly configuration and viewer software with hierarchical user rights
- Detectors for object detection
- Powerful part-finding
- Precise position determination: X/Y-position and orientation
- Comprehensive logic functions for digital switching outputs

Optical data		Functions	
Resolution	736 x 480 pixels	Number of jobs / detectors	2 / 32
CMOS	1/3", monochrome	Detectors	Contour; pattern comparison, contrast, brightness, grey level
Integrated lens, focal length	6 mm, adjustable focal position	Properties	Pattern comparison / contour: teach-in and detection of patterns and contours; grey threshold, brightness: evaluation of brightness; contrast: evaluation of contrast
Adjustment range	6 mm to infinity	Typical cycle times	Typ. 40 ms pattern comparison Typ. 60 ms contour Typ. 4 ms brightness Typ. 4 ms contrast Typ. 4 ms grey threshold
Integrated illumination	White, red, infrared LEDs		
Minimum field of view, X x Y	5 x 4 mm <sup>2</sup>		
Electrical data		Mechanical data	
Operating voltage, +U <sub>B</sub>	18 ... 26.4V DC <sup>1</sup>	Dimensions	65 x 45 x 45 mm <sup>3</sup> (without plug)
Current consumption (without illumination and I/O)	≤ 120 mA	Enclosure rating	IP 67
Current consumption (without I/O)	≤ 200 mA	Material, housing	Aluminium, plastic
Protective circuits	Reverse-polarity protection, U <sub>B</sub> / short-circuit protection of all outputs	Material, front screen	Plastic
Readiness delay	Ca. 13 s after Power on	Ambient temperature: operation	0 ... +50 °C <sup>2</sup>
Outputs	PNP / NPN (switchable)	Ambient temperature: storage	-20 ... +60 °C <sup>2</sup>
Max. output current (per output)	50 mA, 100 mA (pin 12)	Weight	Ca. 160 g
Inputs	PNP/NPN High > U <sub>B</sub> -1V, Low < 3V	Plug connections	Supply and I/O M12, 12-pin Ethernet M12, 4-pin
Input resistance	> 20 kOhm	Vibration and impact resistance	EN 60947-5-2
Encoder input	High > 4V		
Interfaces: VISOR® V10-OB-Standard	Ethernet (LAN), EtherNet/IP		
Inputs/outputs	2 inputs, 4 outputs, 2 selectable inputs/outputs		

<sup>1</sup> Max. ripple < 5V<sub>SS</sub>    <sup>2</sup> 80 % air humidity, non-condensing

Illumination	Depth of field	Part number	Article number
White	Normal	V10-OB-S1-W6	535-91008
Red	Normal	V10-OB-S1-R6	535-91010
Infrared	Normal	V10-OB-S1-I6	535-91046

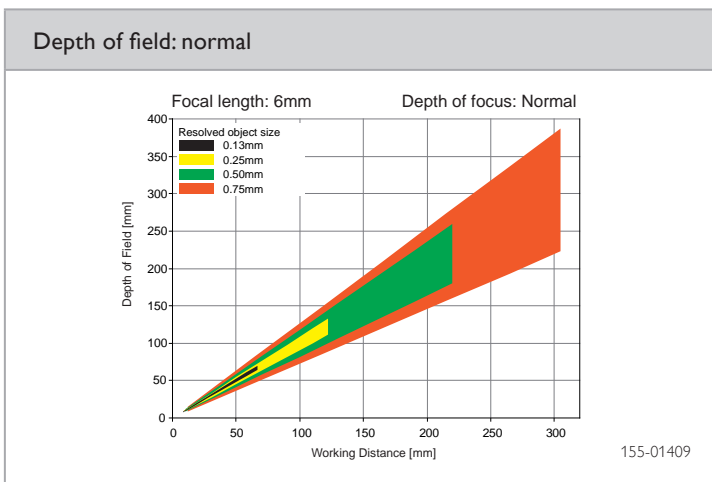
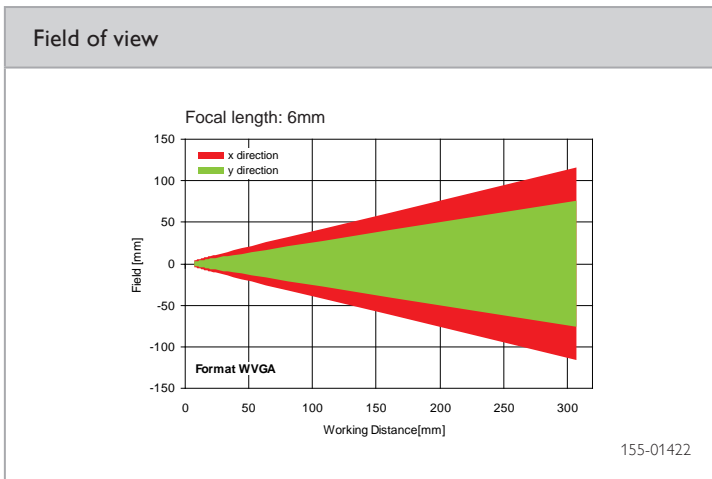
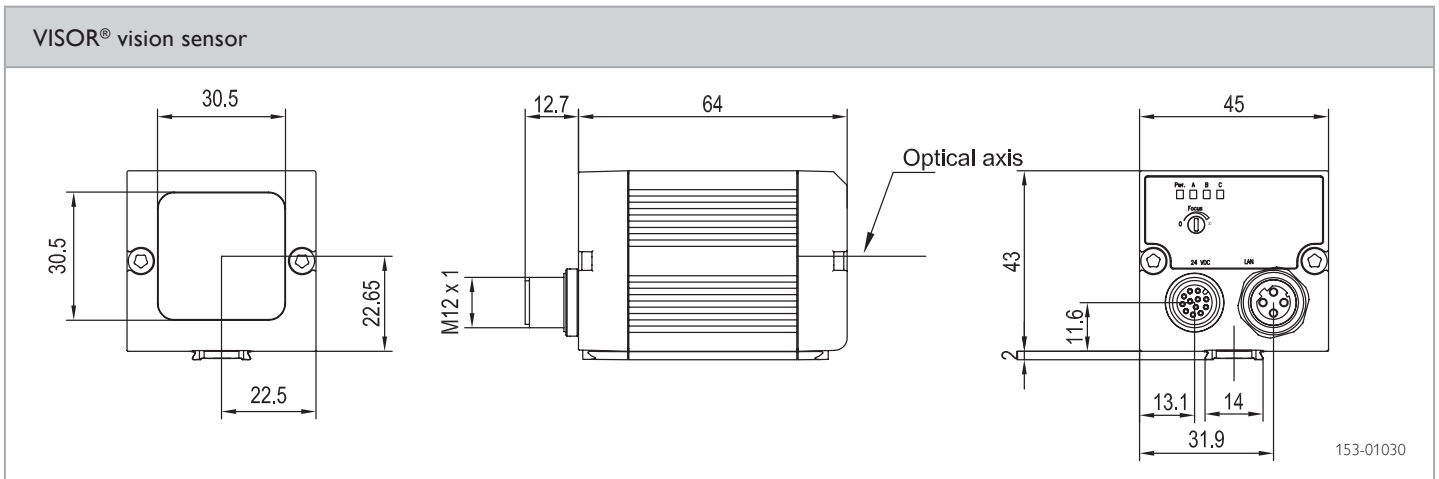

**Accessories**

Connection cables	See product catalog/ accessories
Illumination	
Brackets	
Interface accessories	

# VISOR® V10 object sensor

Standard vision sensor for object detection, 12 mm



## PRODUCT HIGHLIGHTS

- User-friendly configuration and viewer software with hierarchical user rights
- Detectors for object detection
- Powerful part-finding
- Precise position determination: X/Y-position and orientation
- Comprehensive logic functions for digital switching outputs

Optical data		Functions	
Resolution	736 x 480 pixels	Number of jobs / detectors	2 / 32
CMOS	1/3", monochrome	Detectors	Contour, pattern comparison, contrast, brightness, grey level
Integrated lens, focal length	12 mm, adjustable focal position	Properties	Pattern comparison / contour: teach-in and detection of patterns and contours; grey threshold, brightness: evaluation of brightness; contrast: evaluation of contrast
Adjustment range	30 mm to infinity	Typical cycle times	Typ. 40 ms pattern comparison Typ. 60 ms contour Typ. 4 ms brightness Typ. 4 ms contrast Typ. 4 ms grey threshold
Integrated illumination	White, red, infrared LEDs		
Minimum field of view, X x Y	8 x 6 mm <sup>2</sup>		
Electrical data		Mechanical data	
Operating voltage, +U <sub>B</sub>	18 ... 26.4V DC <sup>1</sup>	Dimensions	65 x 45 x 45 mm <sup>3</sup> (without plug)
Current consumption (without illumination and I/O)	≤ 120 mA	Enclosure rating	IP 67
Current consumption (without I/O)	≤ 200 mA	Material, housing	Aluminium, plastic
Protective circuits	Reverse-polarity protection, U <sub>B</sub> / short-circuit protection of all outputs	Material, front screen	Plastic
Readiness delay	Ca. 13 s after Power on	Ambient temperature: operation	0 ... +50 °C <sup>2</sup>
Outputs	PNP / NPN (switchable)	Ambient temperature: storage	-20 ... +60 °C <sup>2</sup>
Max. output current (per output)	50 mA, 100 mA (pin 12)	Weight	Ca. 160 g
Inputs	PNP/NPN High > U <sub>B</sub> -1V, Low < 3V	Plug connections	Supply and I/O M12, 12-pin Ethernet M12, 4-pin
Input resistance	> 20 kOhm	Vibration and impact resistance	EN 60947-5-2
Encoder input	High > 4V		
Interfaces:VISOR® V10-OB-Standard	Ethernet (LAN), EtherNet/IP		
Inputs/outputs	2 inputs, 4 outputs, 2 selectable inputs/outputs		

<sup>1</sup> Max. ripple < 5V<sub>SS</sub>    <sup>2</sup> 80 % air humidity, non-condensing

Illumination	Depth of field	Part number	Article number
White	Normal	V10-OB-S1-W12	535-91009
Red	Normal	V10-OB-S1-R12	535-91011
Infrared	Normal	V10-OB-S1-I12	535-91047

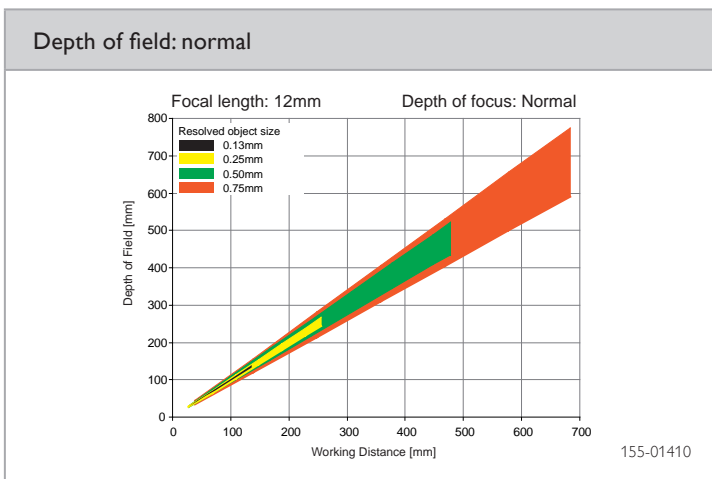
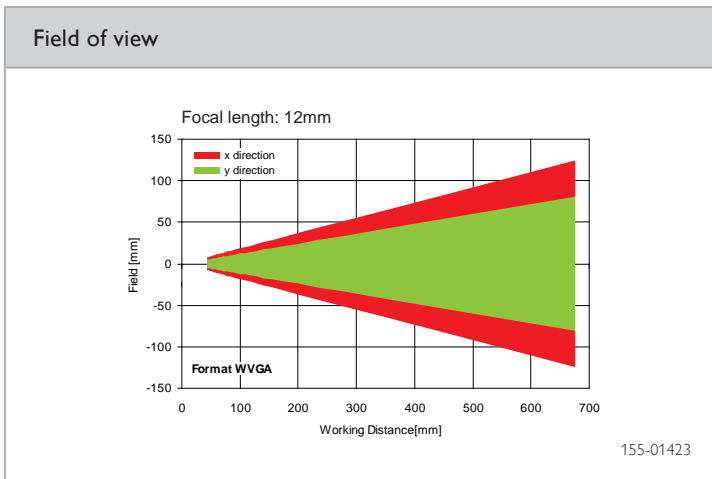
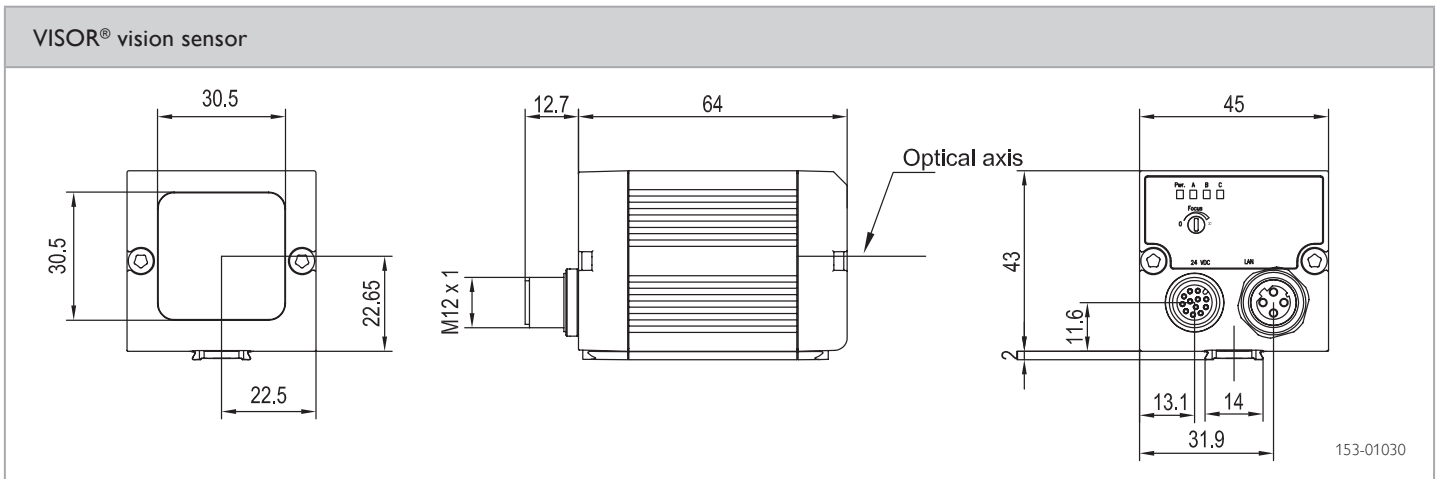

**Accessories**

Connection cables	See product catalog/ accessories
Illumination	
Brackets	
Interface accessories	

# VISOR® V10 object sensor

Advanced vision sensor for object detection, 6 mm



## PRODUCT HIGHLIGHTS

- User-friendly configuration and viewer software with hierarchical user rights
- Detectors for object detection
- Powerful part-finding and tracking
- Precise position determination: X/Y-position and orientation
- Comprehensive logic functions for digital switching outputs
- Encoder input

Optical data		Functions	
Resolution	736 x 480 pixels	Number of jobs / detectors	n / n
CMOS	1/3", monochrome	Detectors	Contour; pattern comparison, contrast, brightness, grey level
Integrated lens, focal length	6 mm, adjustable focal position	Properties	Position tracking: X/Y and orientation; pattern comparison / contour: teach-in and detection of patterns and contours; grey threshold, brightness: evaluation of brightness; contrast: evaluation of contrast
Adjustment range	6 mm to infinity	Typical cycle times	Typ. 20 ms pattern comparison Typ. 30 ms contour Typ. 2 ms brightness Typ. 2 ms contrast Typ. 2 ms grey threshold
Integrated illumination	White, red, infrared LEDs		
Minimum field of view, X x Y	5 x 4 mm <sup>2</sup>		
Electrical data		Mechanical data	
Operating voltage, +U <sub>B</sub>	18 ... 26.4V DC <sup>1</sup>	Dimensions	65 x 45 x 45 mm <sup>3</sup> (without plug)
Current consumption (without illumination and I/O)	≤ 120 mA	Enclosure rating	IP 67
Current consumption (without I/O)	≤ 200 mA	Material, housing	Aluminium, plastic
Protective circuits	Reverse-polarity protection, U <sub>B</sub> / short-circuit protection of all outputs	Material, front screen	Plastic
Readiness delay	Ca. 13 s after Power on	Ambient temperature: operation	0 ... +50 °C <sup>2</sup>
Outputs	PNP / NPN (switchable)	Ambient temperature: storage	-20 ... +60 °C <sup>2</sup>
Max. output current (per output)	50 mA, 100 mA (pin 12)	Weight	Ca. 160 g
Inputs	PNP/NPN High > U <sub>B</sub> -1V, Low < 3V	Plug connections	Supply and I/O M12, 12-pin Ethernet M12, 4-pin Data M12, 5-pin
Input resistance	> 20 kOhm	Vibration and impact resistance	EN 60947-5-2
Encoder input	High > 4V		
Interfaces: VISOR® V10-OB-Advanced	Ethernet (LAN), RS422, EtherNet/IP		
Inputs/outputs	2 inputs, 4 outputs, 4 selectable inputs/outputs		

<sup>1</sup> Max. ripple < 5V<sub>SS</sub>    <sup>2</sup> 80 % air humidity, non-condensing

Illumination	Depth of field	Part number	Article number
White	Normal	V10-OB-A1-W6	535-91001
White	Enhanced	V10-OB-A1-W6D	535-91013
Red	Normal	V10-OB-A1-R6	535-91003
Red	Enhanced	V10-OB-A1-R6D	535-91016

Illumination	Depth of field	Part number	Article number
Infrared	Normal	V10-OB-A1-I6	535-91006
Infrared	Enhanced	V10-OB-A1-I6D	535-91019

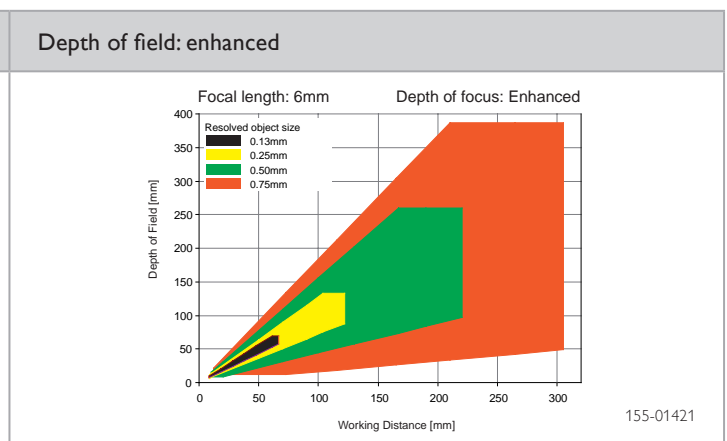
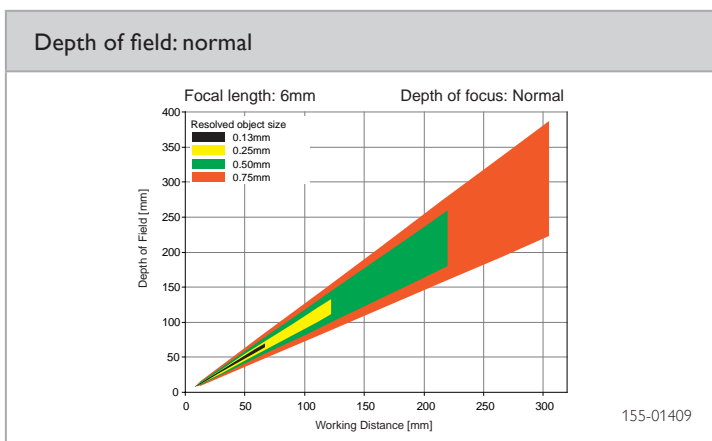
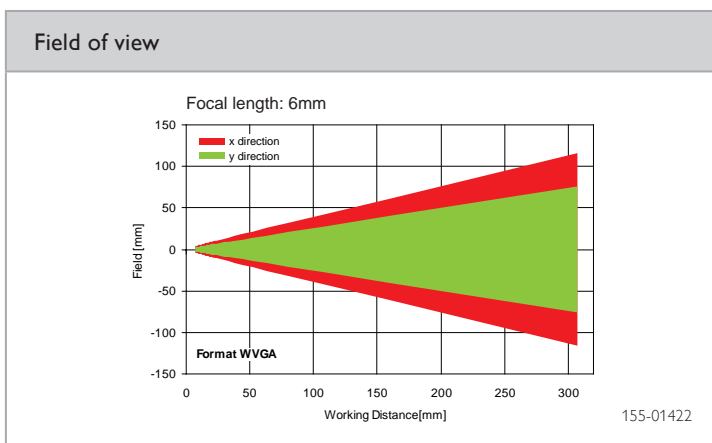
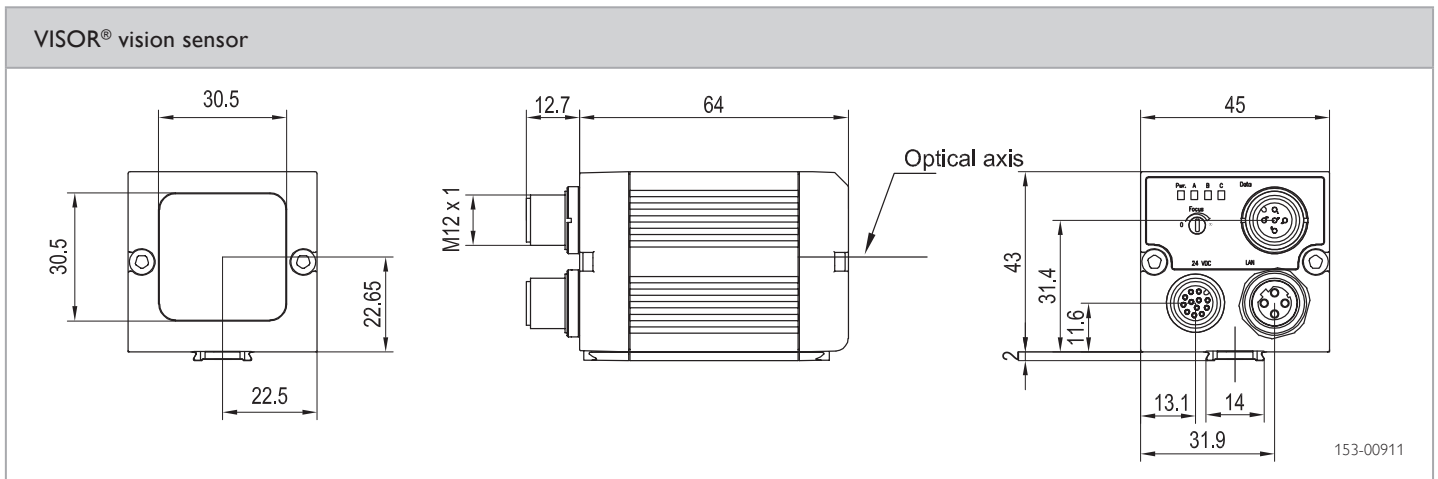

**Accessories**

Connection cables	See product catalog/ accessories
Illumination	
Brackets	
Interface accessories	

# VISOR® V10 object sensor

Advanced vision sensor for object detection, 12 mm



## PRODUCT HIGHLIGHTS

- User-friendly configuration and viewer software with hierarchical user rights
- Detectors for object detection
- Powerful part-finding and tracking
- Precise position determination: X/Y-position and orientation
- Comprehensive logic functions for digital switching outputs
- Encoder input

Optical data		Functions	
Resolution	736 x 480 pixels	Number of jobs / detectors	n / n
CMOS	1/3", monochrome	Detectors	Contour; pattern comparison, contrast, brightness, grey level
Integrated lens, focal length	12 mm, adjustable focal position	Properties	Position tracking: X/Y and orientation; pattern comparison / contour: teach-in and detection of patterns and contours; grey threshold, brightness: evaluation of brightness; contrast: evaluation of contrast
Adjustment range	30 mm to infinity	Typical cycle times	Typ. 20 ms pattern comparison Typ. 30 ms contour Typ. 2 ms brightness Typ. 2 ms contrast Typ. 2 ms grey threshold
Integrated illumination	White, red, infrared LEDs		
Minimum field of view, X x Y	8 x 6 mm <sup>2</sup>		
Electrical data		Mechanical data	
Operating voltage, +U <sub>B</sub>	18 ... 26.4V DC <sup>1</sup>	Dimensions	65 x 45 x 45 mm <sup>3</sup> (without plug)
Current consumption (without illumination and I/O)	≤ 120 mA	Enclosure rating	IP 67
Current consumption (without I/O)	≤ 200 mA	Material, housing	Aluminium, plastic
Protective circuits	Reverse-polarity protection, U <sub>B</sub> / short-circuit protection of all outputs	Material, front screen	Plastic
Readiness delay	Ca. 13 s after Power on	Ambient temperature: operation	0 ... +50° C <sup>2</sup>
Outputs	PNP / NPN (switchable)	Ambient temperature: storage	-20 ... +60° C <sup>2</sup>
Max. output current (per output)	50 mA, 100 mA (pin 12)	Weight	Ca. 160 g
Inputs	PNP/NPN High > U <sub>B</sub> -1V, Low < 3V	Plug connections	Supply and I/O M12, 12-pin Ethernet M12, 4-pin Data M12, 5-pin
Input resistance	> 20 kOhm	Vibration and impact resistance	EN 60947-5-2
Encoder input	High > 4V		
Interfaces: VISOR® V10-OB-Advanced	Ethernet (LAN), RS422, EtherNet/IP		
Inputs/outputs	2 inputs, 4 outputs, 4 selectable inputs/outputs		

<sup>1</sup> Max. ripple < 5V<sub>SS</sub>    <sup>2</sup> 80 % air humidity, non-condensing

Illumination	Depth of field	Part number	Article number
White	Normal	V10-OB-A1-W12	535-91002
White	Enhanced	V10-OB-A1-W12D	535-91014
Red	Normal	V10-OB-A1-R12	535-91004
Red	Enhanced	V10-OB-A1-R12D	535-91017

Illumination	Depth of field	Part number	Article number
Infrared	Normal	V10-OB-A1-I12	535-91007
Infrared	Enhanced	V10-OB-A1-I12D	535-91020

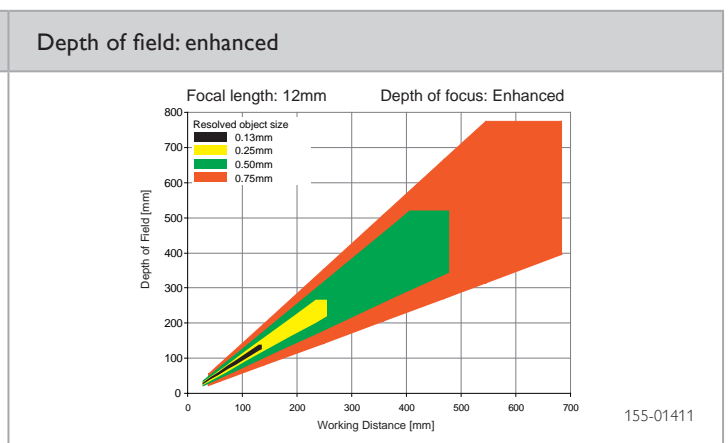
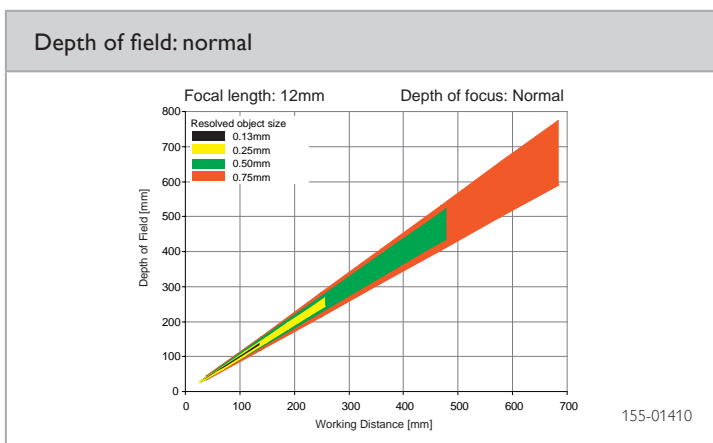
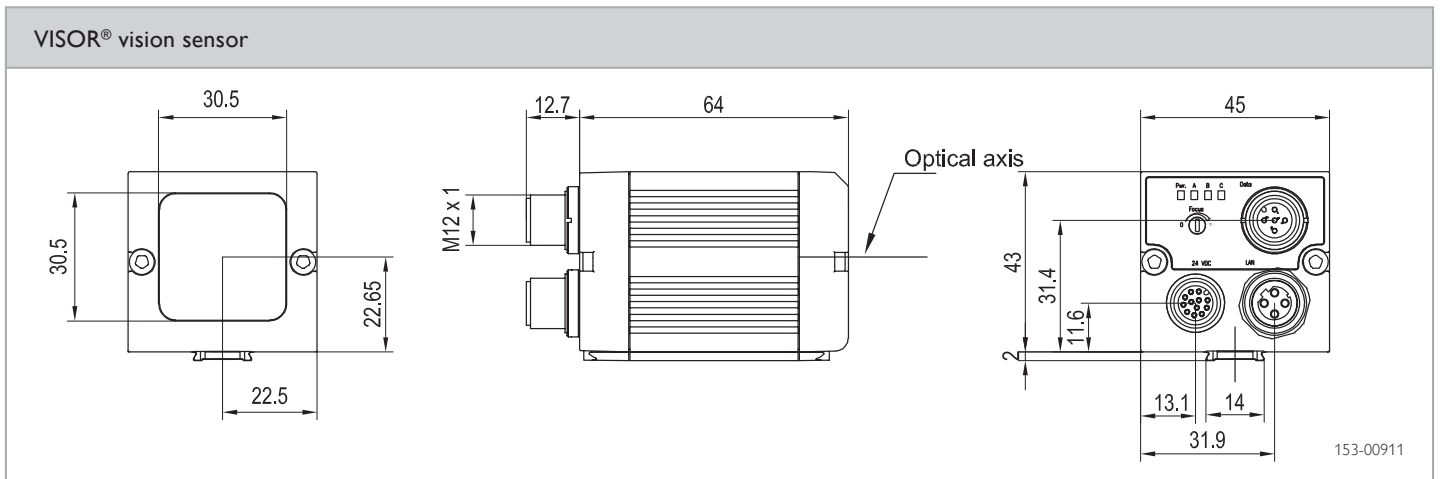

**Accessories**

Connection cables	See product catalog/ accessories
Illumination	
Brackets	
Interface accessories	

# VISOR® V10 object sensor

Advanced vision sensor for object detection, 25 mm



## PRODUCT HIGHLIGHTS

- User-friendly configuration and viewer software with hierarchical user rights
- Detectors for object detection
- Powerful part-finding and tracking
- Precise position determination: X/Y-position and orientation
- Comprehensive logic functions for digital switching outputs
- Encoder input

Optical data		Functions	
Resolution	736 x 480 pixels	Number of jobs / detectors	n / n
CMOS	1/3", monochrome	Detectors	Contour; pattern comparison, contrast, brightness, grey level
Integrated lens, focal length	25 mm, adjustable focal position	Properties	Position tracking: X/Y and orientation; pattern comparison / contour: teach-in and detection of patterns and contours; grey threshold, brightness: evaluation of brightness; contrast: evaluation of contrast
Adjustment range	140 mm to infinity	Typical cycle times	Typ. 20 ms pattern comparison Typ. 30 ms contour Typ. 2 ms brightness Typ. 2 ms contrast Typ. 2 ms grey threshold
Integrated illumination	White, red, infrared LEDs		
Minimum field of view, X x Y	18 x 14 mm <sup>2</sup>		
Electrical data		Mechanical data	
Operating voltage, +U <sub>b</sub>	18 ... 26.4V DC <sup>1</sup>	Dimensions	65 x 45 x 45 mm <sup>3</sup> (without plug)
Current consumption (without illumination and I/O)	≤ 120 mA	Enclosure rating	IP 67
Current consumption (without I/O)	≤ 200 mA	Material, housing	Aluminium, plastic
Protective circuits	Reverse-polarity protection, U <sub>b</sub> / short-circuit protection of all outputs	Material, front screen	Plastic
Readiness delay	Ca. 13 s after Power on	Ambient temperature: operation	0 ... +50 °C <sup>2</sup>
Outputs	PNP / NPN (switchable)	Ambient temperature: storage	-20 ... +60 °C <sup>2</sup>
Max. output current (per output)	50 mA, 100 mA (pin 12)	Weight	Ca. 160 g
Inputs	PNP/NPN High > U <sub>b</sub> -1 V, Low < 3 V	Plug connections	Supply and I/O M12, 12-pin Ethernet M12, 4-pin Data M12, 5-pin
Input resistance	> 20 kOhm	Vibration and impact resistance	EN 60947-5-2
Encoder input	High > 4V		
Interfaces:VISOR® V10-OB-Advanced	Ethernet (LAN), RS422, EtherNet/IP		
Inputs/outputs	2 inputs, 4 outputs, 4 selectable inputs/outputs		

<sup>1</sup> Max. ripple < 5 V<sub>SS</sub>    <sup>2</sup> 80 % air humidity, non-condensing

Illumination	Depth of field	Part number	Article number
White	Normal	V10-OB-A1-W25	535-91012
Red	Normal	V10-OB-A1-R25	535-91015
Infrared	Normal	V10-OB-A1-I25	535-91018

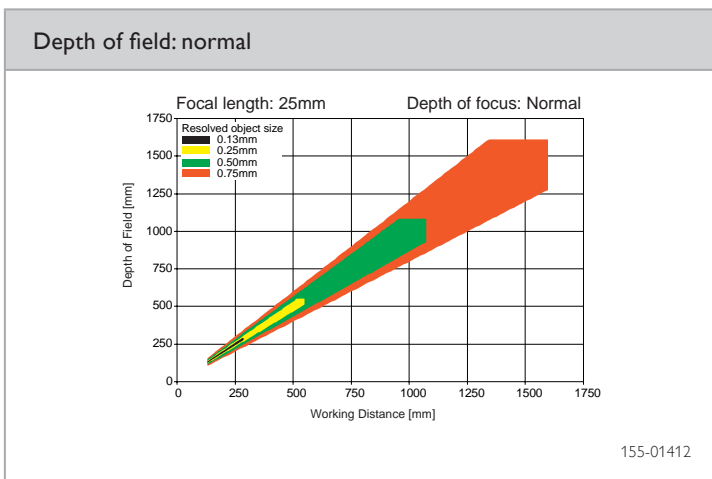
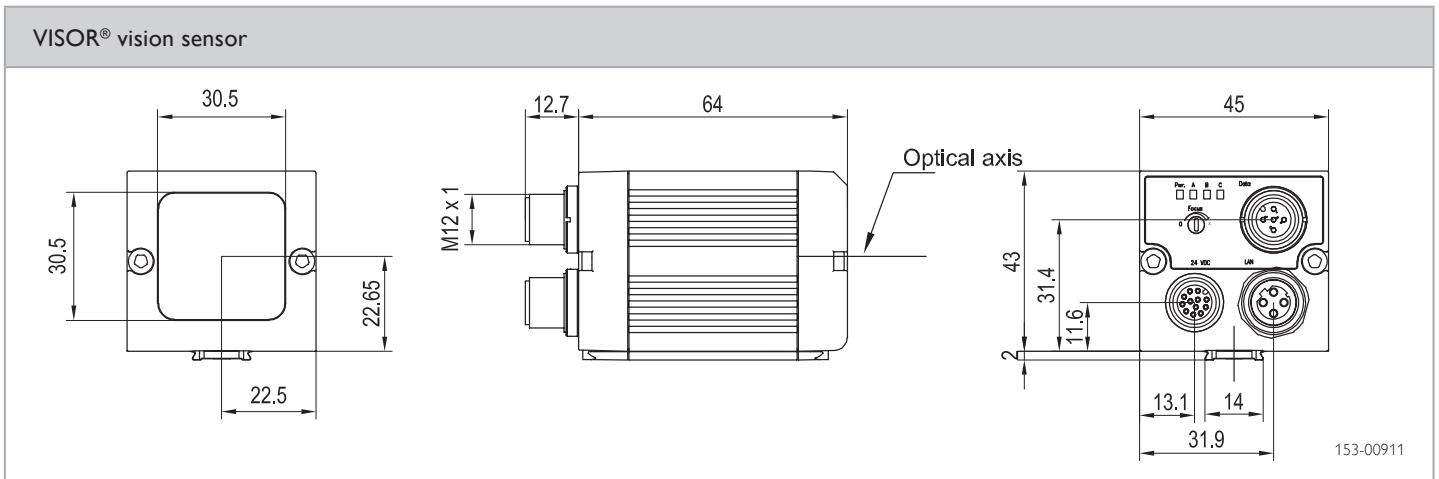

**Accessories**

Connection cables	See product catalog/ accessories
Illumination	
Brackets	
Interface accessories	

# VISOR® V10 object sensor

Advanced vision sensor for object detection, C-mount



## PRODUCT HIGHLIGHTS

- User-friendly configuration and viewer software with hierarchical user rights
- Detectors for object detection
- Powerful part-finding and tracking
- Precise position determination: X/Y-position and orientation
- Comprehensive logic functions for digital switching outputs
- Encoder input

Optical data		Functions	
Resolution	736 x 480 pixels	Number of jobs / detectors	n / n
CMOS	1/3", monochrome	Detectors	Contour; pattern comparison, contrast, brightness, grey level
Integrated lens, focal length	C-Mount	Properties	Position tracking: X/Y and orientation; pattern comparison / contour: teach-in and detection of patterns and contours; grey threshold, brightness: evaluation of brightness; contrast: evaluation of contrast
Adjustment range	Dependent on lens	Typical cycle times	Typ. 20 ms pattern comparison Typ. 30 ms contour Typ. 2 ms brightness Typ. 2 ms contrast Typ. 2 ms grey threshold
Integrated illumination	None		
Minimum field of view, X x Y	Dependent on lens		
Electrical data		Mechanical data	
Operating voltage, +U <sub>B</sub>	18 ... 26.4 V DC <sup>1</sup>	Dimensions	65 x 45 x 45 mm <sup>3</sup> (without plug)
Current consumption (without illumination and I/O)	≤ 120 mA	Enclosure rating	IP 65 <sup>2</sup>
Current consumption (without I/O)	≤ 200 mA	Material, housing	Aluminium, plastic
Protective circuits	Reverse-polarity protection, U <sub>B</sub> / short-circuit protection of all outputs	Material, front screen	Plastic
Readiness delay	Ca. 13 s after Power on	Ambient temperature: operation	0 ... +50 °C <sup>3</sup>
Outputs	PNP / NPN (switchable)	Ambient temperature: storage	-20 ... +60 °C <sup>3</sup>
Max. output current (per output)	50 mA, 100 mA (pin 12)	Weight	Ca. 160 g
Inputs	PNP/NPN High > U <sub>B</sub> -1 V, Low < 3 V	Plug connections	Supply and I/O M12, 12-pin Ethernet M12, 4-pin Data M12, 5-pin
Input resistance	> 20 kOhm	Vibration and impact resistance	EN 60947-5-2
Encoder input	High > 4V		
Interfaces: VISOR® V10-OB-Advanced	Ethernet (LAN), RS422, EtherNet/IP		
Inputs/outputs	2 inputs, 4 outputs, 4 selectable inputs/outputs		

<sup>1</sup> Max. ripple < 5 V<sub>SS</sub>    <sup>2</sup> With LPT45 C-mount protective casing    <sup>3</sup> 80 % air humidity, non-condensing

Part number	Article number
V10-OB-A1-C	535-91005

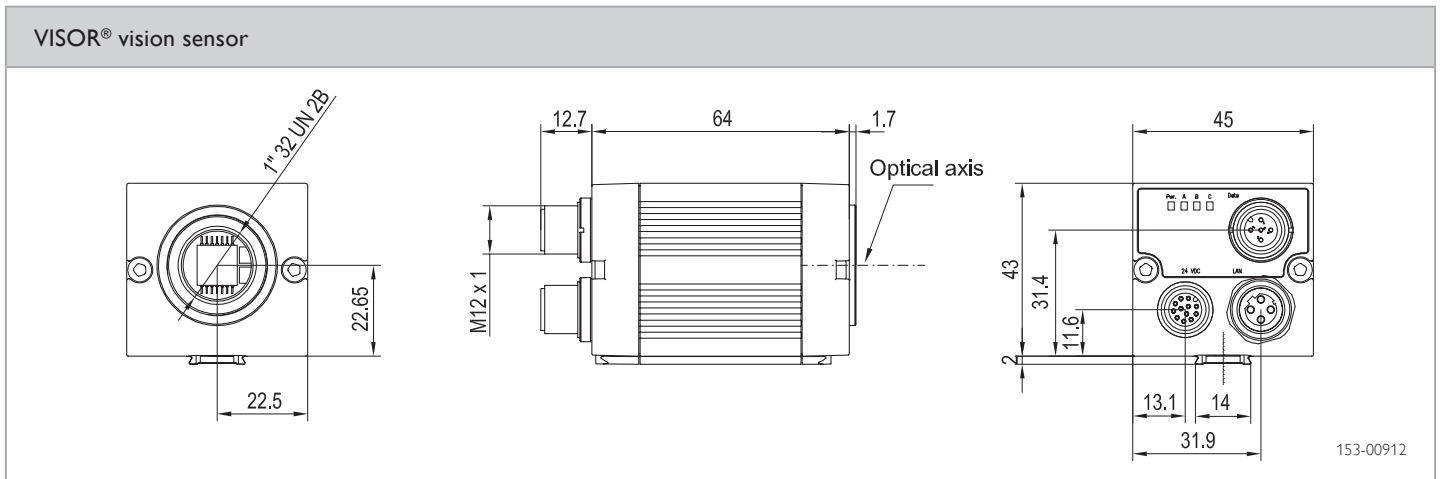

	LO C 8	LO C 12	LO C 16	LO C 25	LO C 50
<b>Focal length</b>	8 mm	12 mm	16 mm	25 mm	50 mm
<b>Article number</b>	526-51513	526-51514	526-51515	526-51516	526-51113

**Accessories**

Connection cables	See product catalog/ accessories
Illumination	
Lenses	
Brackets	
Interface accessories	

# We look ahead.

Yesterday, today and in the future.



“We gauge ourselves not by what is possible today, but by our vision of what can be achieved” – this has been our motto since the foundation of SensoPart in 1994. Our goal is to always be a step ahead and to be able to offer our customers the most innovative sensor for industrial automation.

With our easy to integrate VISOR® Vision sensors and our compact laser sensors with an amazing background suppression made in Germany, we stick up to this motto.

Get ready – we still have a lot of ideas for the future.

## SENSOR TECHNOLOGY

- Light barriers
- Proximity switches
- Laser sensors
- Miniature sensors
- Distance sensors
- Colour sensors
- Contrast sensors
- Anti-collision sensors
- Slot sensors
- Fibre-optic amplifiers
- Inductive sensors
- Capacitive sensors
- Ultrasonic sensors

## VISION

- Vision sensors
- Smart cameras
- Vision systems
- Object detection
- Object measurement
- Colour detection
- Code reading
- Lighting
- Lenses

**Germany**  
SensoPart  
Industriesensorik GmbH  
79288 Gottenheim  
Tel. +49 7665 94769-0  
info@sensopart.de

**France**  
SensoPart France SARL  
77420 Champs sur Marne  
Tel. +33 164 730061  
info@sensopart.fr

**Great Britain**  
SensoPart UK Ltd.  
Burton on Trent, DE14 2WQ  
Tel. +44 1283 567470  
uk@sensopart.com

**USA**  
SensoPart Inc.  
Perrysburg OH 43551  
Tel. +1 866 2827610  
usa@sensopart.com

**China**  
SensoPart (Shanghai) Co. Ltd.  
201803 Shanghai  
Tel. +86 21 31261880  
china@sensopart.com